



Les Équipements Qué-Mont inc.

7475 Boul. Thimens

St-Laurent, Qc H4S 2A2

ASCOT Member of the
Ascot Corporation

TÉL. : (514) 331-0302

FAX : (514) 745-3109

FAX : (888) 745-3109

WATTS 1-800-361-1932

Email : info@quemont.com

Breakdown

285B

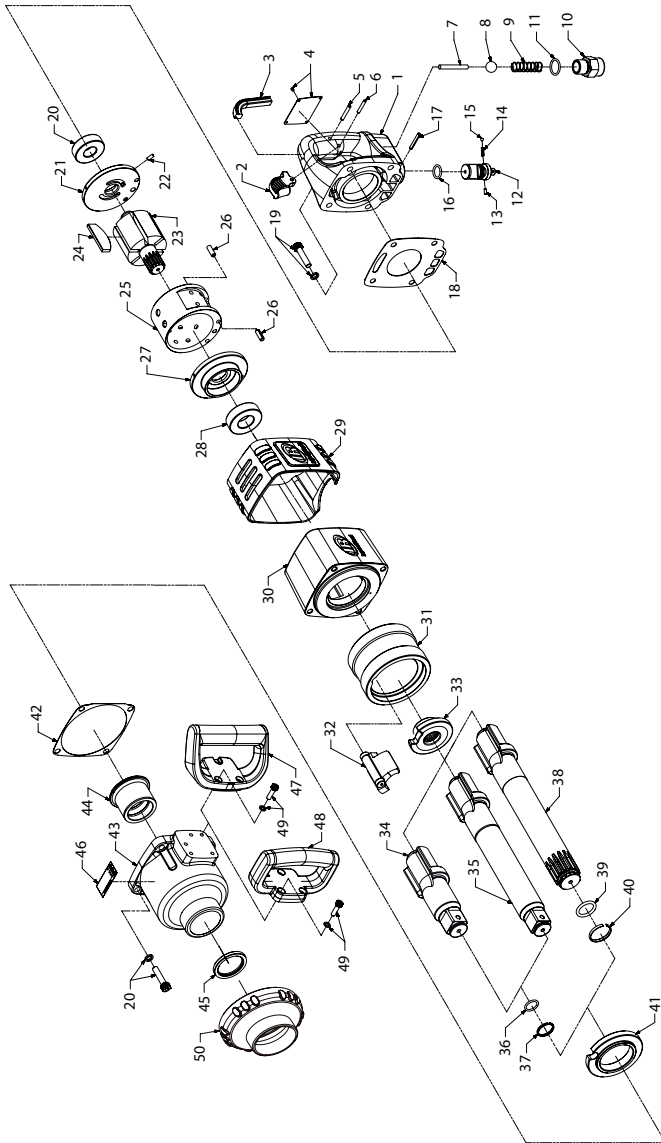

Item	Part Description	Part Number	Item	Part Description	Part Number
1	Trigger Handle Assembly	285B-A92A	28	Front Rotor Bearing	285B-96
2	Trigger	285B-93A	29	Tool Guard	431L-32
3	Slot Cover	285B-438	30	Motor Housing	285B-40
4	Nameplate and 4 rivets	285B-A301	31	Hammer Frame	285B-703
5	Stop Pin	285B-439	32	Hammer	285B-724
6	Pin, Spring	285B-437	33	Hammer Cam	285B-721
7	Plunger, Throttle Valve	285B-302	34	Anvil Assembly	
8	Throttle Valve	285B-50	34	Standard length	285B-A726
9	Spring, Throttle Valve	285B-51	35	6" Extended length	285B-A726-6
10	Inlet Bushing Assembly	285B-A565	36	O-Ring	BBFM-557
11	O-Ring	285B-566	37	Retainer Ring	910E5-918
12	Reverse Valve Assembly	285B-A329	38	6" Extended, #5 Spline	285B-A514-6
13	Stop Pin	285B-332	39	O-Ring	285B-S-557
14	Spring	285B-334	40	Retainer Ring	285B-S-918
15	Ball	285B-333	41	Side Plate	285B-706
16	Reverse Valve Seal	285B-338	42	Hammer Case Gasket	285B-36
17	Pin, Spring	285B-120	43	Hammer Case Assembly	285B-A727
18	Gasket, Handle	285B-283	44	Hammer Case Bushing	285B-641
19	Handle Capscrew and Washer (set of 8)	285B-A638	45	Oil Seal	285B-642
20	Rear Rotor Bearing	285B-24	46	Warning Label	WARNING-2-99
21	End Plate with alignment pin	285B-A12	47	Dead Handle (angled) with screws	285B-A48-6
22	Pin, Spring	---	48	Dead Handle (straight) with screws	285B-A48
23	Rotor	285B-53	49	Screw and Washer (set of 3)	---
24	Vane Pack (set of 6)	285B-42-6	50	Hammer Case Guard	431L-62
25	Cylinder and alignment pins	285B-A3	-	Tune up Kit (includes items 3, 7, 8, 9, 11, 13, 14, 15, 16, 17, 18, 20, 24, 28, 36, 37, 42 and 45)	285B-TK1
26	Pin, Spring	---			
27	Front End Plate	285B-11			

Parts and Maintenance

When the life of the tool has expired, it is recommended that the tool be disassembled, degreased and parts be separated by material so that they can be recycled.

Tool repair and maintenance should only be carried out by an authorized Service Center.

Refer all communications to the nearest **Ingersoll Rand** Office or Distributor.

Related Documentation

For additional information refer to:

Air Impact Wrench Product Safety Information Manual 04580916.

Air Impact Wrench Product Information Manual 45573011.

Manuals can be downloaded from www.irtools.com.